

### Related concepts

Corpuscle, scattering, Compton wavelength,  $\gamma$ -quanta, de Broglie wavelength, Klein-Nishina formula.

### Principle

The energy of scattered  $\gamma$ -radiation is measured as a function of the angle of scatter. The Compton wavelength is determined from the measured values.

### Equipment

PULSE HEIGHT ANALYSER	09102.93*	1
GAMMA DETECTOR	09101.00	1
OPERATING UNIT F.GAMMA DETECTOR	09101.93*	1
MAGNETIC BASE FOR 09053.88	09053.01	1
SOURCE HOLDER FOR 09053.01	09053.04	1
HIGH-VOLTAGE CONNECTING CABLE	09101.10	1
SCREENED CABLE, BNC, L 750 MM	07542.11	1
SCREENED CABLE, BNC, L 1500 MM	07542.12	1
XYT RECORDER	11413.97	1
OSCILLOSCOPE, 20 MHZ, 2 CHANNELS	11454.93*	1
LEAD BRICK WITH HOLE	09021.00	1
LEAD BLOCK, 200X100X50 MM	09029.11	1
SCREEN.CYLINDER F.GAMMA DETECTOR	09101.11	1
SOURCE CS-137, 3.7 MBQ	09096.02	1
AMERICIUM-241 SOURCE, 370 KBQ	09090.11	1
SOURCE CS-137, 37KBQ	09096.01	1
SOURCE NA-22, 185 KBQ	09047.12	1

ROD, IRON, D 25 MM, L 200 MM	09101.13	1
CONNECTING CORD, 500 MM, RED	07361.01	2
CONNECTING CORD, 500 MM, BLUE	07361.04	2

The equipment marked\* is designed for connection to 220 V ac 50 Hz mains. It can also be supplied for other mains voltages or frequencies.

### Problem

1. Calibrate the measuring set-up with the aid of a Cs-137 calibrating source (37 kBq), an Am-241 source (370 kBq) and a Na-22 source (185 kBq).
2. Measure the energy of the Cs-137 661.6 keV peaks scattered at different angles and calculate the Compton wavelength from the readings taken.

### Set-up and procedure

Set up the apparatus as shown in Fig. 1.

The NaI scintillation detector is a highly sensitive instrument and must be treated with care. In particular, avoid mechanical impacts and large changes of temperature. The working instrument for the detector may be switched on only after the detector has been connected.

1. To calibrate the measuring set-up, stick the pellet-shaped Cs-137 source

Fig. 1 Experimental set-up studying the Compton effect.

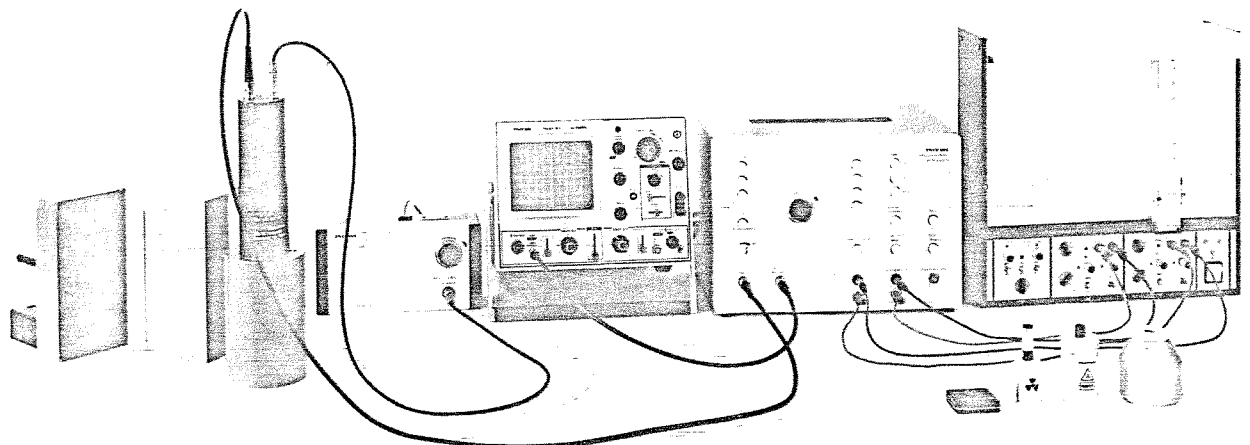

## 5.2.12 Compton effect

directly in front of the inlet opening using a piece of adhesive tape. Set the detector operating voltage initially to 8.00. Pulses will now be seen on the oscilloscope. Adjust the amplification factor on the pulse height analyser so that the clearly visible 661 keV pulses attain an amplitude to about  $9 V_{pp}$ . Sometimes it may be necessary to alter the detector operating voltage.

Set the window width on the pulse height analyser to 5% and select the operating mode "Main".

Using the knob marked "Basis", now search for the 661 keV peak on the plotter (plotter sensitivity  $x$ : approx. 10 mV/cm;  $y$ : approx. 500 mV/cm). Position the pen on the right-hand edge of the 661 keV peak using the "Basis" knob, and then adjust the  $x$ -sensitivity of the plotter so that the pen is situated approximately on the right-hand end of the recording sheet. Then switch to automatic operation and keep the "Null" button depressed. Now, using the zero adjuster of the plotter, position the pen on the starting point on the left-hand side of the recording sheet.

Once the setting has been made, the detector voltage, basis, amplification and  $x$ -sensitivity may not be altered.

For the energy calibration of the set-up, record the 661.6 keV line of Cs-137 and (at higher  $y$ -sensitivity) the 32 keV line of Cs-137, the 59.6 keV line of Am-241 and the 511 keV line of Na-22 using automatic operation (clock 0.8 s).

- For the measurements it is recommended to prepare a diagram corresponding to that shown in Fig. 2. Place the diagram on the surface of the table and arrange the source, the substance used to scatter the  $\gamma$ -radiation, and the detector on top of the diagram at the appropriate angle. Push the source into the opening of the lead brick to about the centre.

As additional shielding from direct radiation, place an extra lead brick between the source and the detector, and arrange it in such a way that di-

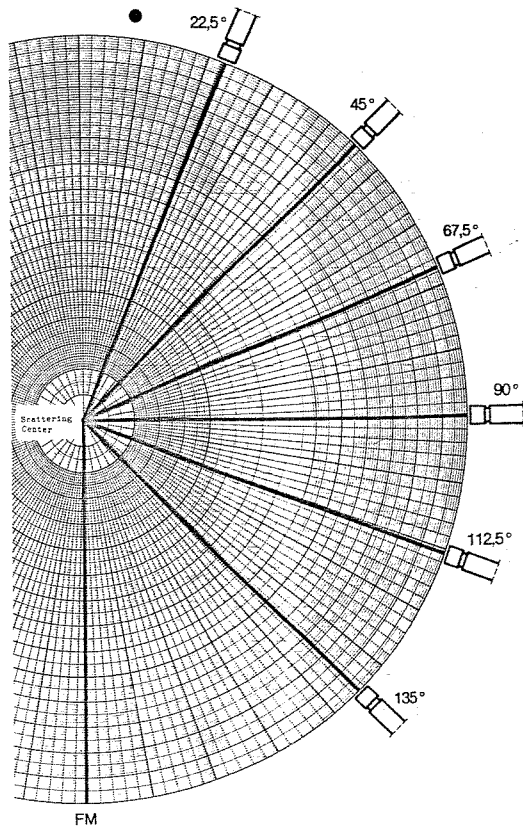

Fig. 2 Polar diagram for geometrical arrangement of detector, scattering medium and source

rect radiation has as long a path as possible in the lead.

The positioning of the lead brick is crucial, in that Compton scattering also occurs in the lead. If necessary, try out several positions.

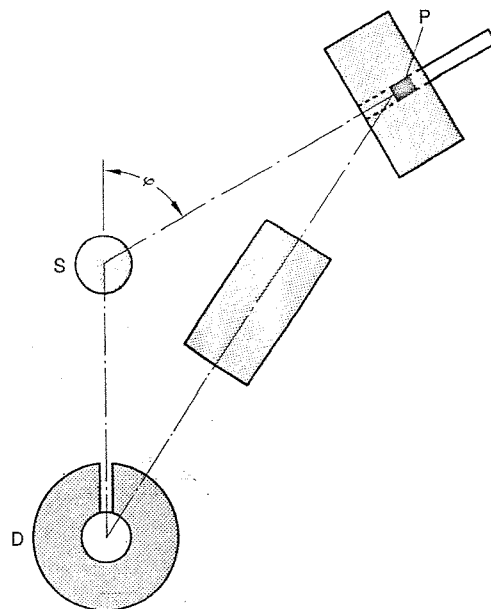

Fig. 3 Arrangement of the extra lead brick for shielding direct radiation (P = source, S = scattering medium, D = detector)

## 5.2.12 Compton effect

During the experiment ensure that no other sources are situated in the immediate vicinity of the detector, or even further away from it. Since only the Compton peak is of interest, other regions can be skipped over using the "Vorlauf" (= Forward Run) button. However, it is important to mark the zero point for every trace (for subsequent evaluation).

It is recommended to repeat all the angular settings several times. The small angles  $22.5^\circ$  and  $45^\circ$  are especially crucial.

### Theory and evaluation

The collision of a photon or a  $\gamma$ -quantum with a free electron which gives rise to a directional change of the  $\gamma$ -quantum is called Compton scattering. From the laws of conservation of energy and momentum, the wavelength of the  $\gamma$ -quantum will be increased. This change of wavelength is dependent upon the angle of scatter and is given by the expression:

$$\Delta\lambda = \Lambda (1 - \cos \Phi),$$

where

$$\Lambda = \frac{h}{m c}$$

is the Compton wavelength of the electron,  $h$  is Planck's constant,  $m$  is the rest mass of the electron, and  $c$  is the velocity of light.  $\Phi$  is the angle between the incident and scattered wave.

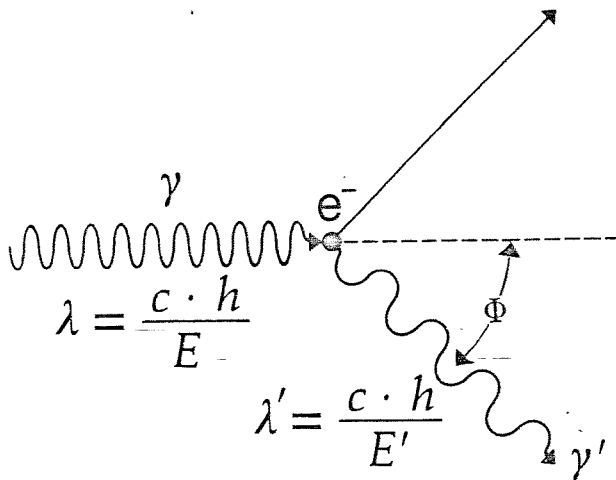

Fig. 4 Change of wavelength during Compton collision

1. The set-up is calibrated by recording peaks of known energy: Cs-137, Am-241 and Na-22. Plot the energies on a graph as a function of the position of the plotter ( $x$ ).

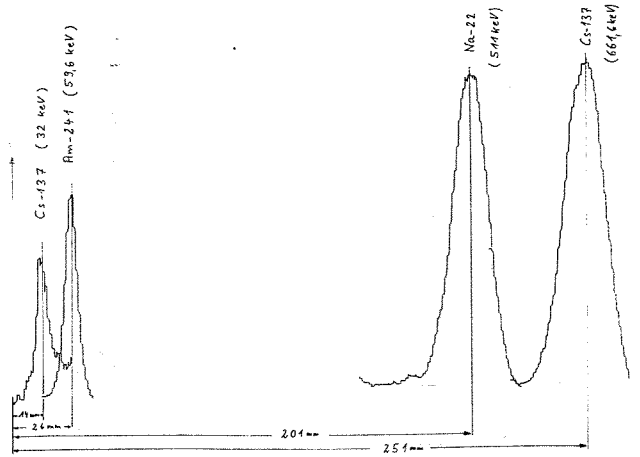

Fig. 5 Energy of known peaks as a function of the position of the plotter

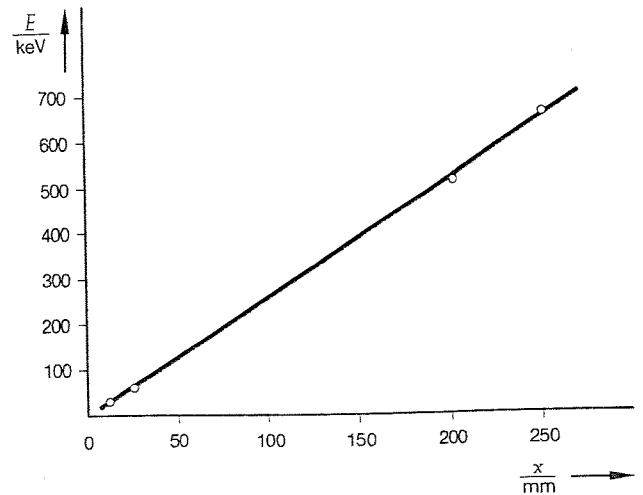

Fig. 6 Calibration diagram; plot of peaks of known energy

Determine the slope either graphically or by linear regression with the expression  $E = a + bx$ . Using the values from Fig. 6, this gives:

$$b = 2.63 \frac{\text{keV}}{\text{mm}} \text{ with the standard}$$

deviation

$$s_b = 0.05 \frac{\text{keV}}{\text{mm}}.$$

2. Determine the line centre of the measured scattering peaks graphically and, taking the calibration factor  $b$

## 5.2.12 Compton effect

and the distance  $s$  from the origin, calculate the energy  $E = s b$  in each case. Calculate the de Broglie wavelength for the individual energies using the expression

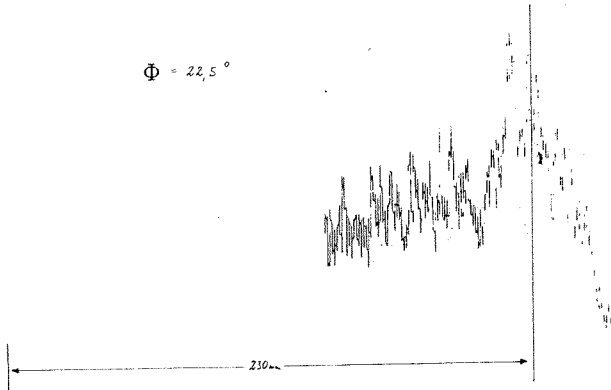

Fig. 7 Scattering peak at  $22.5^\circ$

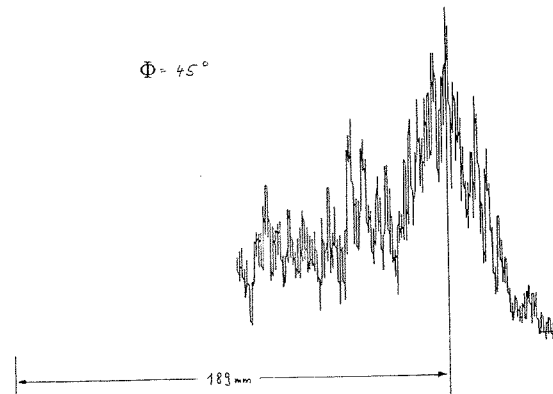

Fig. 8 Scattering peak at  $45^\circ$

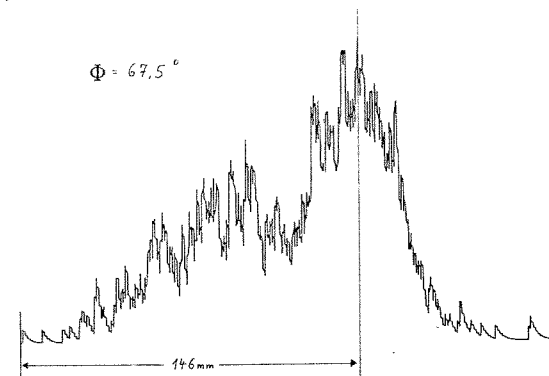

Fig. 9 Scattering peak  $67.5^\circ$

$$\lambda = \frac{h c}{E}$$

$$\begin{aligned} ( \quad h &= 6.625 \cdot 10^{-34} \text{ Js}^2; \\ \quad c &= 2.997 \cdot 10^8 \text{ ms}^{-1}; \\ 1 \text{ keV} &= 1.602 \cdot 10^{-16} \text{ Js} ) . \end{aligned}$$

From the difference of wavelength  
 $\Delta\lambda = \lambda - \lambda_0$ , ( $\lambda_0 = 1.873 \cdot 10^{-12} \text{ m} \approx 661.6 \text{ keV}$ ),

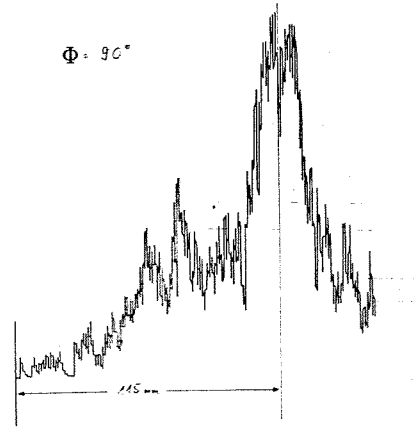

Fig. 10 Scattering peak  $90^\circ$

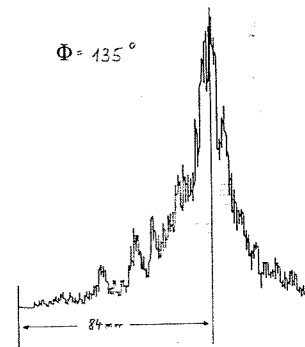

Fig. 11 Scattering peak  $112.5^\circ$

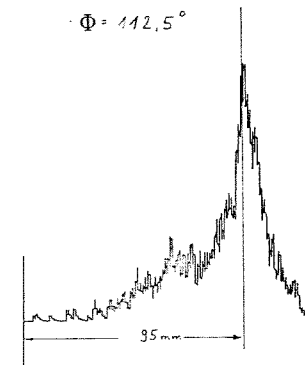

Fig. 12 Scattering peak  $135^\circ$

calculate for each angle  $\Phi$  the Compton wavelength

$$\Lambda = \frac{\Delta\lambda}{1 - \cos\Phi}$$

With the values from Fig. 7 to Fig. 12, a mean value

$$\Lambda = (2.36 \pm 0.14) \text{ pm}$$

is obtained. (Literature value:  $2.462 \text{ pm}$ ).

### Literature

- Melissinos, A.C. Experiments in modern physics, Academic Press, New York, 1966.