

## Determining the velocity of light with a periodic light signal at small distances

### Objects of the experiments

- Measuring the phase shift  $\Delta\varphi$  of a periodic light signal on a path  $\Delta s$ .
- Determining the velocity of light  $c$ .

### Principles

A periodic light signal with the time-dependent intensity

$$I = I_0 + \Delta I_0 \cdot \cos(2\pi \cdot \nu \cdot t) \quad (I)$$

is extremely well suited for determining the velocity of light  $c$ . The light signal is measured with a receiver, which converts the signal into an alternating voltage with the time behaviour

$$U = a \cdot \cos(2\pi \cdot \nu \cdot t) \quad (II)$$

If the receiver is at the distance  $\Delta s$  from the light transmitter, the time delay

$$\Delta t = \frac{\Delta s}{c} \quad (III)$$

of the signal along the path  $\Delta s$  leads to the phase shift

$$\Delta\varphi = 2\pi \cdot \nu \cdot \Delta t = 2\pi \cdot \frac{\Delta t}{T} \quad (IV)$$

$\nu$ : modulation frequency

$T$ : period

Excepting possible losses in intensity, the receiver measures the phase-shifted signal

$$U = a \cdot \cos(2\pi \cdot \nu \cdot t - \Delta\varphi) \quad (V)$$

From (III) and (IV) the following equation, which determines the velocity of light, is obtained

$$c = \frac{\Delta s}{\Delta\varphi} \cdot 2\pi \cdot \nu \quad (VI)$$

If the modulation frequency is very high, considerable phase shifts  $\Delta\varphi$  are achieved on short paths  $\Delta s$ . In the experiment,  $\nu$  is equal to 60 MHz. The path  $\Delta s = 5$  m therefore corresponds to a phase shift by a full period.

However, the high frequency makes it more difficult to display the receiver signal with an oscilloscope. As a simple oscilloscope will be used for determining the phase shift, the receiver signal will be mixed (multiplied) electronically with a signal of the frequency  $\nu' = 59.9$  MHz. From the addition formula

$$\cos \alpha \cdot \cos \alpha' = \frac{1}{2} \cdot (\cos(\alpha + \alpha') + \cos(\alpha - \alpha'))$$

it follows that the mixed signal

$$U = a \cdot \cos(2\pi \cdot \nu \cdot t - \Delta\varphi) \cdot \cos(2\pi \cdot \nu' \cdot t) \quad (VII)$$

can be represented as the sum of two signals, one with the frequency  $\nu + \nu'$  and one with the difference frequency  $\nu_1 = \nu - \nu'$ . The high-frequency part is suppressed with a low-pass filter. Therefore only

$$U_1 = \frac{1}{2} a \cdot \cos(2\pi \cdot \nu_1 \cdot t - \Delta\varphi) \quad (VIII)$$

is left as receiver signal. It can be displayed with a simple oscilloscope since the frequency  $\nu_1$  is only 100 kHz. The phase shift  $\Delta\varphi$  has not been changed by the mixing, but it now corresponds to an *apparent propagation time*  $\Delta t_1$ . The period  $T_1$  of the mixed signal is also read from the oscilloscope, and the phase shift can be calculated:

$$\Delta\varphi = 2\pi \cdot \frac{\Delta t_1}{T_1} \quad (IX)$$

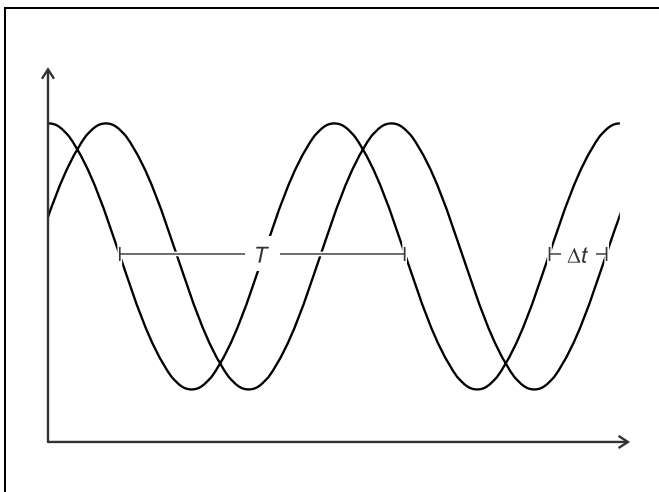

Fig. 1 Phase shift of a periodic light signal

**Apparatus**

1 light transmitter and receiver . . . . .	476 30
1 lens, $f = + 150$ mm . . . . .	460 08
2 saddle bases . . . . .	300 11
1 two-channel oscilloscope 1004 . . . . .	575 221
1 metal scale, 1 m long . . . . .	311 02

For the *actual propagation time*  $\Delta t$  of the light signal along the path  $\Delta s$

$$\Delta t = \Delta t_1 \cdot \frac{T}{T_1} = \frac{\Delta t_1}{T_1 \cdot v} \quad (X)$$

is obtained from (IV) and (IX), and this leads to an equation which determines the velocity of light:

$$c = \frac{\Delta s}{\Delta t_1} \cdot \frac{T_1}{T} = \frac{\Delta s}{\Delta t_1} \cdot T_1 \cdot v \quad (XI).$$

For an exact determination of the phase shift  $\Delta\phi$  a reference signal is available in the experiment. This signal is synchronized with the intensity of the light transmitter. It is mixed with the same 59.9-MHz signal and filtered in the same way as the receiver signal (see Fig. 2). As the propagation times of the

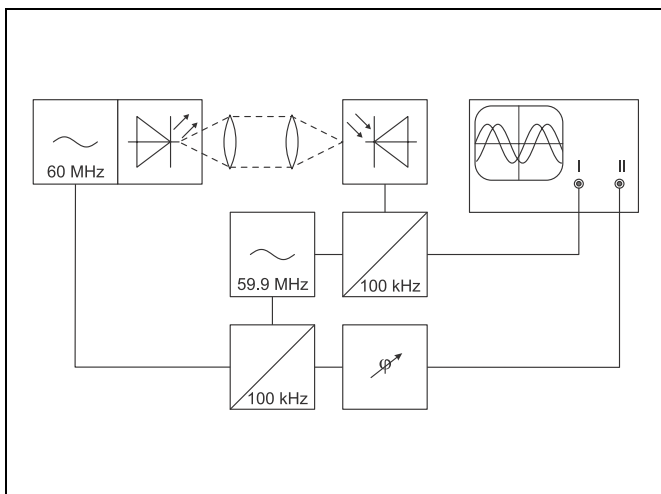

Fig. 2 Block diagram illustrating the measurement of the velocity of light

signals in connection leads and in the apparatus cannot be neglected, the light transmitter is first set up at a distance  $s$  from the receiver. In this arrangement, the reference signal is synchronized with the receiver signal by means of an electronic phase shift. Then the light transmitter is displaced by the path  $\Delta s = 1$  m away from the receiver. The phase shift  $\Delta\phi$  which is now observed is due to the propagation time  $\Delta t$ .

**Setup**

The experimental setup is illustrated in Figs. 3 and 4.

- Place the light transmitter at a distance of approx. 1 m from the receiver, connect it to the output (a) of the receiver via a 6 m long coaxial cable, and switch the receiver on.
- Image the red light patch of the light transmitter on the front plate of the receiver and displace the insert (e) relative to the condensor (d) so that the red light patch is illuminated as evenly as possible.
- Reduce the distance between the light transmitter and the receiver to 50 cm, and place the lens in the ray path.
- Align the light transmitter and the lens so that the red light patch impinges on the entrance aperture of the receiver. If necessary, optimize the alignment of the light transmitter with the knurled screws (f).
- Connect the output (c) of the receiver to channel II of the oscilloscope.

Oscilloscope settings:

Coupling of channel II:	AC
Trigger:	channel II
Time base:	2 $\mu$ s/DIV

- Observe the receiver signal on the oscilloscope and optimize the alignment of the light transmitter and the lens once more.

If the receiver signal is distorted due to overload:

- Slightly defocus the light bundle by displacing the lens.
- Mark the position of the light transmitter on the table as position 1.
- Displace the light transmitter along the optical axis by  $\Delta s = 100$  cm, check the alignment of the light transmitter, and mark the second position, too.

**Carrying out the experiment**

*Remark:*

*A satisfactory accuracy of the result can only be achieved if the light transmitter and the receiver are thermally stable. Start the experiment only half an hour after switching on the light transmitter and the receiver.*

**Synchronizing the phases of the reference and the receiver signal:**

- Connect the output (b) of the receiver to channel I of the oscilloscope and look at channel I (reference signal) and channel II (receiver signal) simultaneously.

Oscilloscope settings:

Coupling channel I and II:	AC
Trigger:	channel I
Time base:	2 $\mu$ s/DIV

- Adjust the vertical positions of channels I and II so that they are as symmetric as possible with respect to the horizontal centre line of the screen.

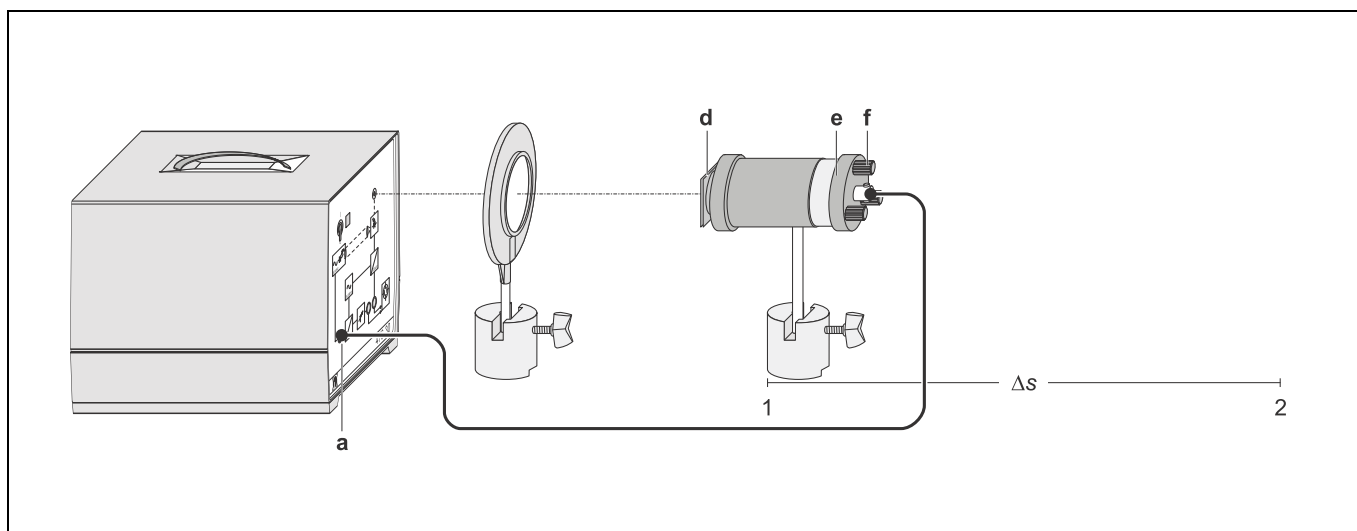

Fig. 3 Optical setup for determining the velocity of light with a periodic light signal.

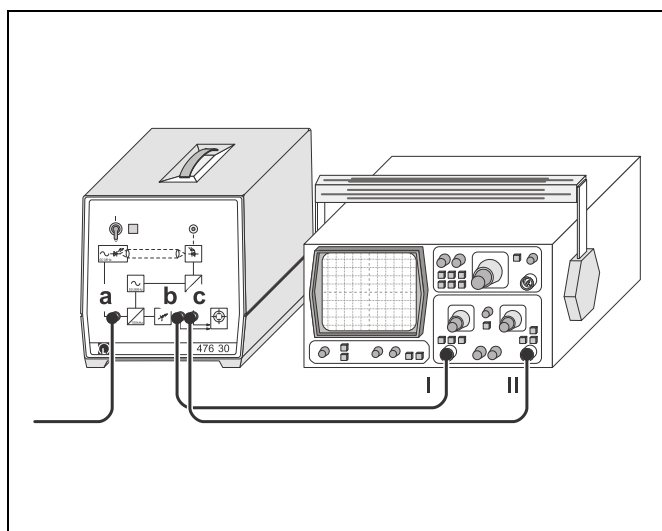

Fig. 4 Connection of the oscilloscope for measuring the phase shift of the periodic light signal.

- For the sake of control adjust the vertical deflections with the fine adjustment control so that the maxima of both signals touch the same horizontal line.
- Adjust the two signals with the phase shifter  $\varphi$  so that they are in phase as exactly as possible.
- Choose a suitable horizontal position of the signals, and determine the period  $T_1$ .

#### Determining the phase shift $\Delta\varphi$ :

- Displace the light transmitter back to position 1, and observe the two signals.
- Set the time base  $0.5 \mu\text{s}/\text{DIV}$ , shift the zero of the reference signal exactly to the vertical centre line, and determine the *apparent propagation time*  $\Delta t_1$ .
- Displace the light transmitter back and forth several times, and determine the mean value of the measured values  $\Delta t_1$ .

#### Measuring example

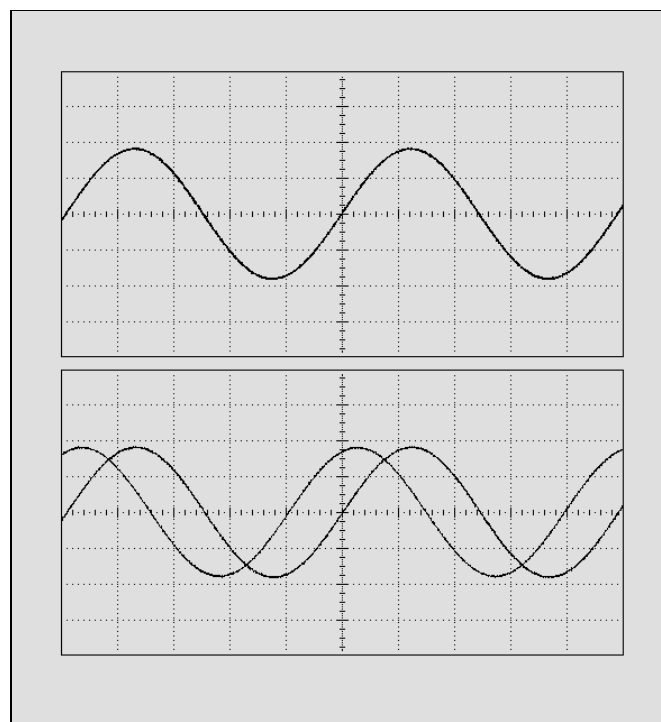

Fig. 5 Reference signal and receiver signal for the positions 1 (above) and 2 (below) of the light transmitter,  $\Delta s = 100 \text{ cm}$ , time base  $2 \mu\text{s}/\text{DIV}$ .

$$\Delta s = (100 \pm 1) \text{ cm}$$

$$\Delta t_1 = (3.9 \pm 0.1) \text{ DIV} \cdot 0.5 \mu\text{s}/\text{DIV} = (1.95 \pm 0.05) \mu\text{s}$$

$$T_1 = (4.90 \pm 0.05) \text{ DIV} \cdot 2 \mu\text{s}/\text{DIV} = (9.8 \pm 0.1) \mu\text{s}$$

Since the modulation frequency  $\nu = 60 \text{ MHz}$  is timed by a quartz, it need not be measured.

**Evaluation**

With (X) the propagation time of the light signal along the path  $\Delta s = 1 \text{ m}$  is calculated:

$$\Delta t = (3.32 \pm 0.09) \text{ ns}$$

The velocity of light is obtained from (XI):

$$c = (3.02 \pm 0.09) \cdot 10^8 \frac{\text{m}}{\text{s}}$$

**Values quoted in the literature:**

Velocity of light in vacuum:

$$c_0 = 2.998 \cdot 10^8 \frac{\text{m}}{\text{s}}$$

Velocity of light in air:

$$c = \frac{c_0}{n} = 2.997 \cdot 10^8 \frac{\text{m}}{\text{s}}$$

(refractive index  $n = 1.003$  under standard conditions)

**Results**

The finite propagation time of light along a certain path manifests itself in the phase shift of a periodic light signal. From the phase shift and the path length the velocity of light can be determined if the period or the frequency, respectively, of the light signal is known.